

322

EXCAVATOR



Bobcat®

Weights

Operating weight with ROPS canopy	1599 kg
Additional weight for cab	109 kg
Additional weight for steel tracks	53 kg

Engine

Make / model	Kubota / D722-E
Fuel / Cooling	Diesel / Liquid
Maximum power	11.7 kW
Torque at 1800 RPM (SAE Net)	43.4 Nm
Number of cylinders	3
Displacement	0.72 l
Bore / Stroke	67 mm / 68 mm
Alternator	12 V — 40 A
Starter	12 V — 1.4 kW

Controls

Steering	Direction and speed controlled by two hand levers or foot pedals
Hydraulics	Two joysticks control boom, bucket, dipperstick and upper structure slew

Hydraulic System

Pump type	Engine-driven triple-section gear pumps
Pump 1 capacity	30.0 l/min at 3000 RPM
Pump 2 and 3 capacity	15.0 l/min at 3000 RPM
Auxiliary flow	30.0 l/min
System relief pressure for implement circuits	172 Bar
System relief pressure for auxiliary circuits	172 Bar
Control valve	Nine-spool parallel type, open centre

Performance

Digging force, dipperstick	8768 N
Digging force, bucket	15160 N
Drawbar pull	16280 N
Ground pressure with rubber tracks	27.4 kPa
Travel speed, low range	1.5 km/h
Travel speed, high range	2.9 km/h
Maximum digging depth	2197 mm

Slew System

Boom swing, left	50°
Boom swing, right	90°
Slew circle	Single row shear-type ball bearings with internal gear
Slew drive	Orbit motor
Slew rate	10.9 RPM

Traction

Track width, rubber, standard	230 mm
Number of track rollers per side	3
Gradeability travelling down or backing up slopes	25°

Brakes

Travel brake	Hydraulic lock on motor
Slew brake	Hydraulic lock on motor and pin lock

Fluid Capacities

Cooling system	5.7 l
Engine lubrication plus oil filter	3.2 l
Fuel reservoir	27.5 l
Hydraulic reservoir	6.5 l
Hydraulic system	18.5 l

Working Range

All dimensions in mm.

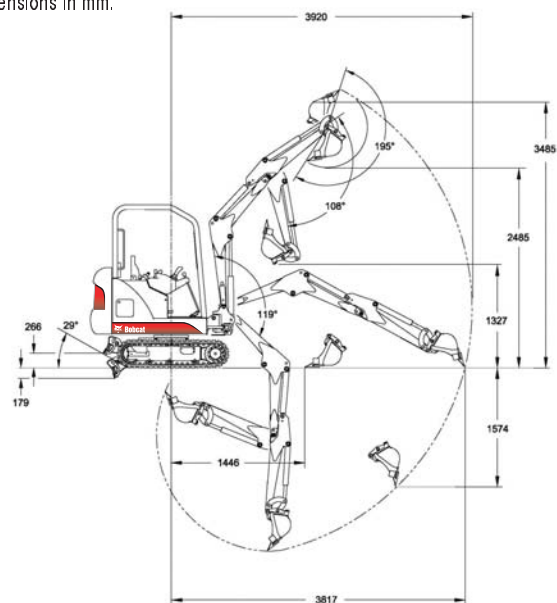
**Dimensions**

All dimensions in mm.

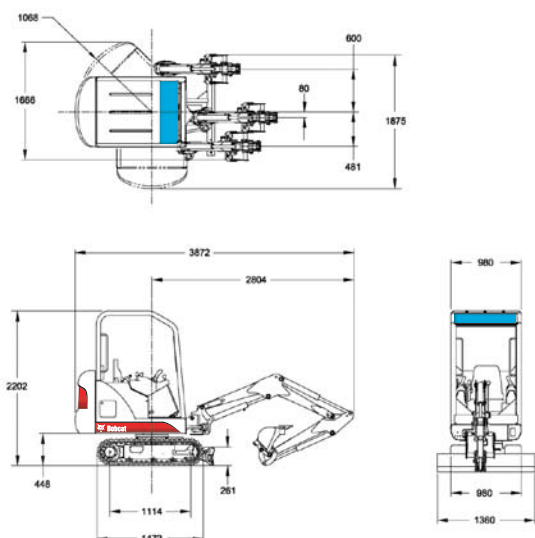
**BOBCAT EUROPE**

J. Huysmanslaan, 59
 B - 1651 LOT Belgium
 Tel. +32 (0)2 371 68 11
 Fax +32 (0)2 371 69 01
 E-mail: bobcat_europe@eu.bobcat.com
 www.bobcat.com

An **IR** Ingersoll-Rand business