

KOMATSU®

PC14R-2

NET POWER
11,2 kW / 14,7 HP @ 2.600 rpm

OPERATING WEIGHT
1.460 kg

BUCKET CAPACITY
0,03 - 0,06 m³

PC
14R-2

MINI-EXCAVATOR



PC14R-2

WALK-AROUND

Tradition and innovation

The new compact mini-excavator is the product of the competence and the technology that KOMATSU has been acquiring for over the past eighty years. The project has been developed with a constant attention to the needs of customers from all over the world; the result is a user-friendly machine, which offers top class performance.

PRECISION

Perfectly in line with Komatsu style... the absolute control is guaranteed by an advanced hydraulic system.

COMFORT

The result of many ergonomic tests is an outstanding comfort which allows the operator to work in the best conditions.

RELIABILITY

High quality standards guarantee longer life to all components, minimizing cost impact due to downtime.



NET POWER

11,2 kW / 14,7 HP @ 2.600 rpm

OPERATING WEIGHT

1.460 kg

BUCKET CAPACITY0,03 - 0,06 m³**V**ERSATILITY

Developed with the aim of getting the best in every application, the PC14R-2 can work in gardens as well as in road sites with great agility.

ACCESSIBILITY

Thanks to the tilting floor the accessibility to all maintenance points has never been so easy and fast.

CUSTOMIZATION

Many different configurations allow every user to customize the machine according to his own requirement.

STRONG POINTS



ABSOLUTE CONTROL

The easiness operation allows also not experienced operator to get the maximum from their job. The controls are user friendly and dedicated for each movement. The smoothness ad the perfect visibility of the working area are the features which guarantee the max productivity also in the toughest situations.

OPERATOR'S ENVIRONMENT

Designed with the utmost attention to detail, the operator's environment ensures that comfort, accessibility and visibility are not compromised. The two pole canopy, or the cab with the wide sliding door, allows easy access to and from the machine. Once seated the spacious and obstacle free floor grants even the tallest operator room to move his legs. The operator's environment is further complemented by the adjustable seat and the ergonomic PPC controls. Two speed tracking (optional) is operated by a switch located on the dashboard where it is possible to monitor all the machine functions.



VARIABLE UNDERCARRIAGE

For the applications requiring maximum versatility in terms of size and stability, the PC14R-2 is available also with hydraulic extension of the undercarriage, which can be easily obtained by operating a push button and the blade control lever from the driver's seat. This device allows to shift from the maximum stability configuration, for working, to the minimum width, less than one meter, to drive through restricted passages or doors.



ROBUSTNESS

Particular technical solutions contribute to increase the sturdiness and the operability of the machine. Among these, we can highlight the cast swing support, that confers extreme rigidity to the structure, and the boom, that lodges the hydraulic hoses, protecting them from possible damages, guaranteeing the best visibility over the digging area.

TILTING FLOOR

All periodic inspection points are easily accessible through the bonnets. In addition, extra-ordinary maintenance can be performed by simply tilting the canopy upwards: under the floor, the operator can find all major hydraulic components, like the main valve or the swing motor. ORFS hydraulic face seal connectors and DT electric connectors improve the reliability of the machine and make repairs easier and faster. Special technical solutions have allowed to extend up to 500 hours the intervals for most ordinary maintenance operations, such as pin greasing or engine oil replacement. Also, to avoid possible leakage, all tanks are equipped with a draining hose: this confirms once again the attention KOMATSU pays to the environment.



CUSTOMIZATION

Many available configurations allow the operator to choose the right machine for the specific job: short or long arm, canopy or cab, rubber or steel shoes, 1 or 2 speed, standard or variable undercarriage. Moreover, the 1 / 2 way auxiliary hydraulic circuit consents to use multiple working tools, like the hammer, the clamshell bucket, the auger, etc.

DIMENSIONS & WORKING RANGE

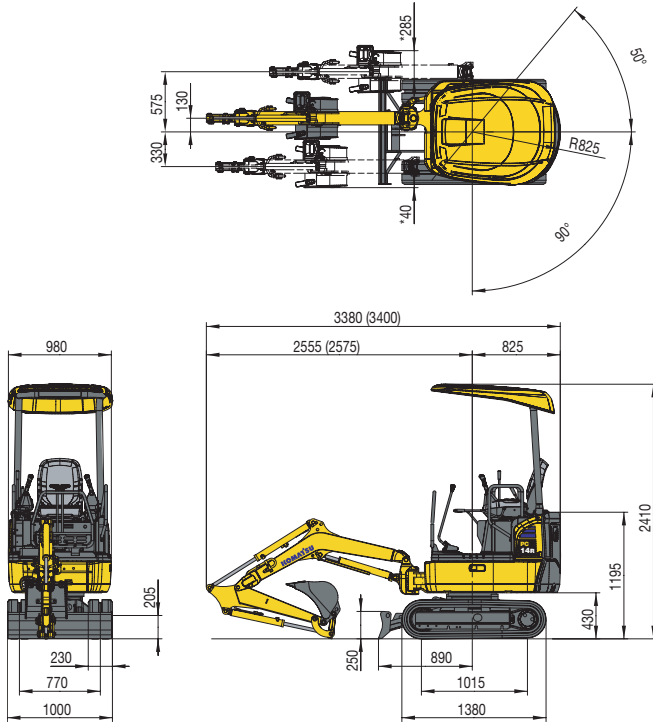

BUCKET RANGE			
Width mm	Capacity m ³ (ISO7451)	Weight kg	No. of teeth
250	0,03	19	2
300	0,035	20	3
350	0,04	22	3
400	0,05	23	3
450	0,06	25	4

PC14R-2: Canopy, Rubber Shoes, 350 mm Bucket, Blade Down

A - Distance from machine's center B - Height at bucket pin

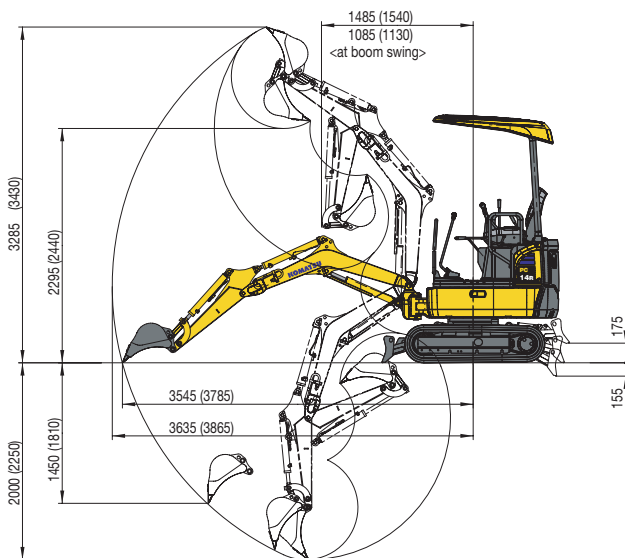

Arm length 880 mm						
A \ B	2 m		2,5 m		Max. outreach	
	Front	360°	Front	360°	Front	360°
2 m	(*)225	(*)225	(*)218	200	(*)220	179
1 m	(*)353	267	(*)266	192	(*)221	143
0 m	(*)424	249	(*)299	182	(*)231	147
-1 m	(*)293	253	-	-	(*)227	215

Unit: kg

Arm length 1.130 mm								
A \ B	2 m		2,5 m		3 m		Max. outreach	
	Front	360°	Front	360°	Front	360°	Front	360°
2 m	-	-	(*)178	(*)178	-	-	(*)184	151
1 m	(*)302	268	(*)235	190	(*)201	141	(*)189	123
0 m	(*)413	243	(*)290	177	(*)218	135	(*)200	125
-1 m	(*)341	242	(*)226	177	-	-	(*)208	170

Unit: kg

NOTE:

Ratings are based on ISO standard 10567. Rated loads do not exceed 87% of hydraulic lift capacity or 75% of tipping load.

- The values marked with an asterisk (*) are limited by the hydraulic capacities - Calculations are based on the machine resting on a uniform and firm surface.
- The lifting point is a hypothetical hook placed behind the bucket.

SPECIFICATIONS



ENGINE

The new generation engine has been developed to comply with the strictest emission controls (STAGE 2).

Model	Komatsu 3D67E-1
Type.....	emissionised 4-cycle diesel engine
Displacement.....	778 cm ³
No. of cylinders	3
Net power (SAE J1349)	11,2 kW / 14,7 HP @ 2.600 rpm
Max. torque	45,6 Nm @ 2.000 rpm
Cooling system.....	water
Air filter type	dry
Starting	electric motor with pre-heating air system for cold climate



OPERATING WEIGHT

Operating weight with standard bucket, fully serviced, +80 kg operator (ISO 6016).

Operating weight with rubber shoes	1.460 kg
Operating weight with steel shoes	1.530 kg
Heated cab weight	+120 kg (optional)
Variable undercarriage	+170 kg



HYDRAULIC SYSTEM

Type.....	Komatsu CLSS
Main pump	1 × gear pump
Max. pump flow.....	40,8 ltr/min
Max. operating pressure	19 MPa (190 bar)
Bucket digging force (ISO 6015)	1.190 daN (1.210 kg)
Arm crowd force (ISO 6015):	

880 mm arm.....	740 daN (750 kg)
1.130 mm arm.....	575 daN (585 kg)

The digging equipment is fully controlled by PPC servo-controls. All movements are stopped by lifting the safety levers on the tiltable case.



TRANSMISSION

Type.....	single speed hydrostatic transmission, controlled and steered by means of two levers or two pedals
Hydraulic motors	2 × axial pistons
Reduction system.....	planetary gear
Max. drawbar pull.....	1.230 daN (1.250 kgf)
Travel speed.....	2 km/h



SWING SYSTEM

The rotation is operated by means of an orbital hydraulic motor. Single ball-bearing ring with internal, induction hardened toothring. Centralised lubrication of the unit.

Swing speed.....	8,9 rpm
------------------	---------



BLADE

Type.....	electro-welded, single unit structure with extensions
Width × height	1.020 × 250 mm
Max. lifting above ground level	175 mm
Max. depth below ground level	155 mm



UNDERCARRIAGE

Track rollers (each side)	3
Shoe width	230 mm
Ground pressure (standard)	0,27 kg/cm ²



ELECTRIC SYSTEM

Voltage	12 V
Battery	41 Ah
Alternator.....	40 A
Starter motor	1,2 kW



SERVICE CAPACITIES

Fuel tank.....	19 ltr
Radiator and system	3,1 ltr
Engine oil (refill)	3,3 ltr
Hydraulic system (refill)	1,2 ltr

MINI-EXCAVATOR

STANDARD EQUIPMENT

- ROPS (ISO 3471) FOPS (ISO 10262) canopy
- Rubber shoes
- 880 mm digging arm
- 1 / 2 way auxiliary hydraulic circuit for attachments up to the boom
- Adjustable seat
- Lifting cylinder guard
- Working light on boom
- Safety valve on bucket element

OPTIONAL EQUIPMENT

- ROPS (ISO 3471) / FOPS (ISO 10262) tilting cab with heating
- Steel shoes
- 1.130 mm digging arm
- Two speeds
- Variable undercarriage
- Bucket range (250 - 450 mm)
- 1.000 mm ditch cleaning bucket
- Travel acoustic alarm
- Extension of the auxiliary hydraulic circuit up to the arm, with quick couplings
- Rotating beacon
- Biodegradable oil
- Rear-view mirrors



Manufacturer: Komatsu Utility Europe

Head Office · via Atheste 4 · 35042 Este (Padova) - Italy

Tel. +39 0429 616111 · Fax +39 0429 601000 · www.komatsueurope.com · utility@komatsu.it

Call the experts



Komatsu Europe International NV

Mechelsesteenweg 586
 B-1800 VILVOORDE (BELGIUM)
 Tel. +32-2-255 24 11
 Fax +32-2-252 19 81
www.komatsueurope.com

WESS004900 02/2006

Materials and specifications are subject to change without notice.

KOMATSU is a trademark of Komatsu Ltd. Japan.