

TB016

STANDARD FEATURES

- Hydraulically expandable track frame
- Long track frame gives extra stability
- Emergency engine shutdown system
- Electronic engine monitoring system
- Cast iron wrap around protective counterweight
- Steel engine cover
- Automatic fuel bleed system
- Variable displacement piston pumps
- Safety lockout lever for travel and operating controls
- Remote slew lubrication system
- Two way auxiliary hydraulics plumbed to dipper arm
- Two speed travel
- Double flanged track rollers
- Spring applied, hydraulically released disc type parking and slew brakes
- Precise response, proportional main control valves
- Simultaneous operation of cab swing and two digging functions with no reduction in working speed
- Cushioned main boom and swing cylinders
- Hydraulic oil cooler
- Protective routing of bucket, arm and auxiliary hydraulic hoses
- Adjustable pilot operated joystick controls with arm rest
- Main boom cylinder guard
- Hydraulic and fuel sight gauges
- Low noise level and EPA exhaust emission compliant engine
- Engine oil 'Safedrain' system
- Maintenance free battery
- TOPS/FOPS cab or canopy
- Fully adjustable suspension seat
- Uncluttered operators platform with hand and foot operated travel controls
- Vandalism protected lockable fuel tank and engine compartment
- Lockable operator's manual and tool storage compartments
- Boom mounted work lights
- Entry from both sides on canopy models
- Short pitch rubber tracks

OPTIONS

- TKB71 Hydraulic Breaker

In accordance with our established policy of constant improvement, we reserve the right to amend these specifications at any time without notice. Photographs shown may feature non-standard equipment.

TAKEUCHI

Takeuchi Mfg (UK) Ltd, Lynroyle Way, Rochdale, Lancs OL11 3EX Tel: 01706 657722 Fax: 01706 657744
 e-mail: sales@takeuchi-mfg.co.uk www.takeuchi-mfg.co.uk
 Southern Depot at Thatcham, Newbury Tel: 01635 877 196 Fax: 01635 877 195

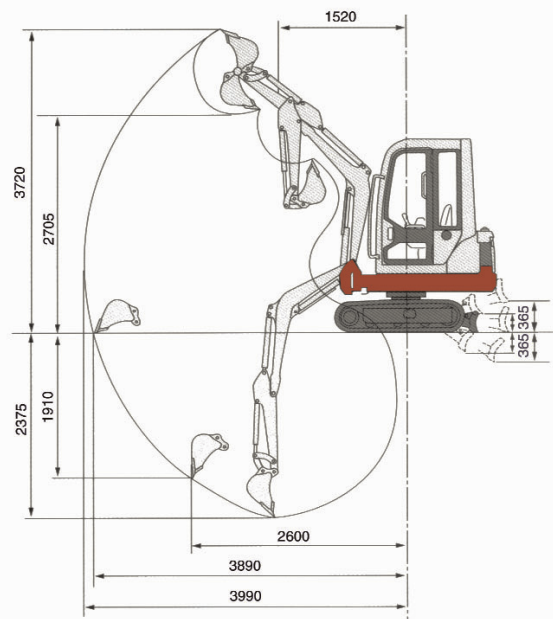
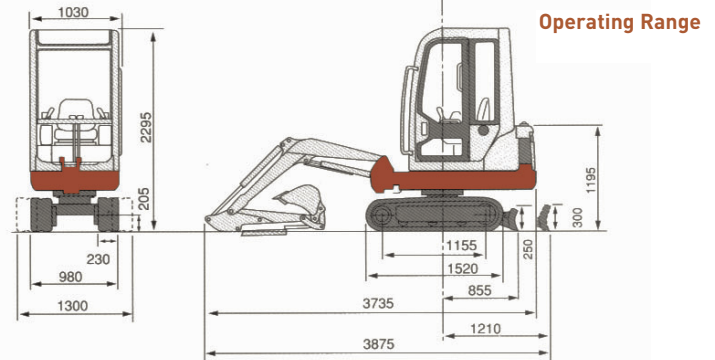
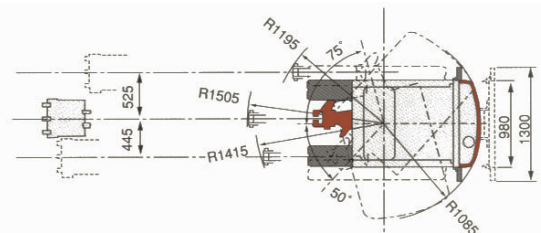

All Dimensions unless otherwise stated are in millimeters

DIMENSIONS & WEIGHT		OPERATING INFORMATION	
Operating Weight (kg)		Max. Dig Depth	2375
Cab/Canopy	1615/1500	Max. Dump Height	2705
Length (transport)	3875	Max. reach at ground level	3890
Width	1030	Max. Vertical Dig Depth	1910
Height (Cab/Canopy)	2295/2280	Max. Bucket Dig Force (Kn)	13.1
Ground Clearance	205	Max. Arm Dig Force (Kn)	9
Min front swing radius (Cab/Canopy)	1210/1050	UNDERCARRIAGE	
Tail swing radius	1085	Traction Motor	Axial Piston
Dozer Blade (wxh)	980-1300x300	Traction Drive	Planetary
ENGINE		Traction Brake	Disc
Make/Model	Yanmar3TNE68-NTB	Track Width	230
Rated Output/RPM	9kW/2300	Ground Contact Length	1155
Maximum Torque	51Nm	Ground Pressure (kpa)	24.9
Cylinders/Displacement	3/784cc	Travel Speed (K/ph)	2.4/4.6
Electrical System	12volt 40amp	Maximum Gradeability	30°
SWING SYSTEM		HYDRAULIC SYSTEM	
Boom Swing angle (L/R)	75°/50°Cab90°/50°Canopy	Set Pressure (bar)	200
Slew Speed (rpm)	9	Pump Type	Variable(P1+P2)+Gear(P3)
Slew Motor	Orbital Piston	Hydraulic Flow (l/min)	16.4x2+10.1
Slew Brake	Disc	Auxiliary Flow (l/min)	33
		CAPACITIES (l)	
		Hydraulic system	33.5
		Fuel tank	21
		Engine Lubrication	2.8
		Cooling System	2.9